



**Asia-Pacific
Economic Cooperation**

2010/SOM3/CTI/WKSP/009

APEC Single Window Vision - Ongoing Work at the SCCP

Submitted by: Japan



**Ease of Doing Business Workshop on Trading
Across Borders
Sendai, Japan
18-19 September 2010**

APEC Single Window Vision

- Ongoing work at the SCCP -



Hidetoshi Aramaki

**Assistant to the Chair
Sub-Committee on Customs Procedures (SCCP)**

**Deputy Director, Customs Cooperation Division
Customs and Tariff Bureau, MOF, Japan**

18 September, 2010

1

Single Window Working Group (SWWG) Phase 1 (2006-2007)

SWWG Phase 1 Achievements (2006 - 2007)

■ SW Strategic Plan

- **“SW VISION”** to develop single window system that facilitate legitimate trade and enhance supply chain security in two stages:
 - Stage 1 – Within APEC Economies
 - Stage 2 – Between SW Systems

- **“Recommendations”** for moving forward
 - 1: WG creation
 - 2: Adoption of the UN/CEFACT definition
 - 3: Use of internationally recognized instruments & Standards
 - 4: Establish a repository to capture information regarding SW related initiatives
 - 5: Capacity building activities
 - 6: Roadmap

Single Window Working Group (SWWG) Phase 2 (2008-2009)

SWWG Phase 2 Achievements (2008 - 2009)

■ Single Window Implementation Guide

- Technical components that could be included as part of a SW system
- Roadmap with core elements that an economy need to consider in the development of a SW system

■ Capacity building activities (4 workshops)

■ Single repository at the WCO

(http://www.wcoomd.org/sw_overview_apec.htm)

Single Window Agenda at the SCCP Progress in 2010

CAP Evaluation Report Single Window Report

“A Stock-Taking Study on the Development of Single Window System & Collective Action Plan (CAP)”

- ✓ **Updated:**
Developed this year and approved at the SCCP2 (September 15-17)
- ✓ **Reliable :**
Direct responses from Customs Authorities
- ✓ **Comprehensive :**
Covers all APEC 21 Economies

Single Window Agenda at the SCCP Progress in 2010

CAP Evaluation Report (Paperless Trading Environment)

(Major Findings)

- ✓ Complete Paperless : 5 Economies
- ✓ Require Hardcopies under Certain Condition : 10 Economies
- ✓ Require Hardcopies : 6 Economies

Single Window Agenda at the SCCP Progress in 2010

CAP Evaluation Report (Paperless Trading Environment)

(Major Findings)

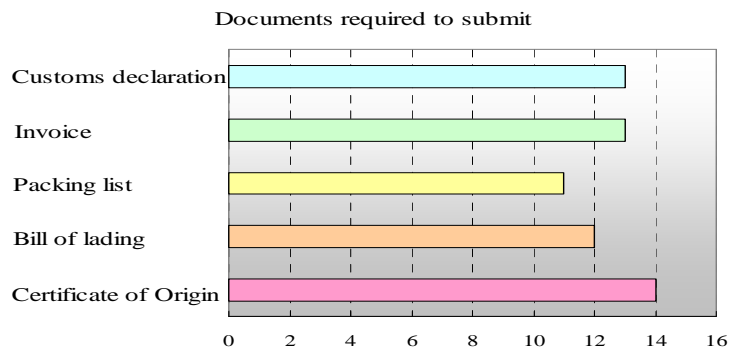

Single Window Agenda at the SCCP Progress in 2010

Single Window Report

(Major Findings)

- Adoption of Computerized Customs Clearance System :
19 Economies (2004)  21 Economies (2010)
- More than 90% of Electronically Lodged Customs Declaration (both Import & Export)
16 Economies (2010)

Single Window Agenda at the SCCP Progress in 2010

Single Window Report

(Major Findings)

- Developed & Operated Single Window system
6 Economies (2006)  13 Economies (2010)

Single Window Agenda at the SCCP Progress in 2010

Single Window Report

(Major Findings)

- No. of the other Government Agencies Linked with the Single Window System
 - ✓ More than 80% : 4 Economies
 - ✓ 50% - 80% : 5 Economies
 - ✓ 10% - 50% : 7 Economies
 - ✓ Less than 10% : 5 Economies

Single Window Agenda at the SCCP Progress in 2010

Single Window Report

(Major Findings)

- Harmonization with Internationally Recognized Standards (WCO Data Model, UN/EDIFACT etc.)
 - 17 Economies (2010)
- Information Exchange Through the SW
 - 10 Economies (2010)

Single Window Agenda at the SCCP Challenges Agreed

**APEC Customs Directors-General/Commissioners
Meeting**
(September 14)
SCCP2
(September 15-17)

(Agreed to)

- **Develop a SW System in Each Economy
by 2020**
- **Promote International Interoperability
between the SW Systems**

Single Window System in Japan More User Friendly and Less Cost

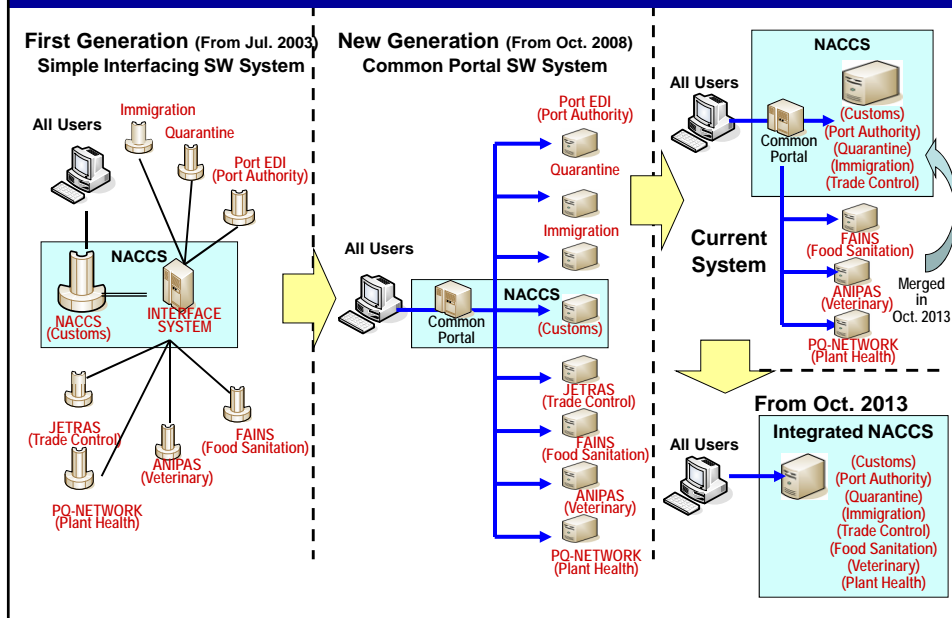

Thank you very much !



Hidetoshi Aramaki
Deputy Director
Office of Regional Customs Cooperation
Customs and Tariff Bureau, MOF, Japan
apec@mof.go.jp